

## Special Bore Measurement

Although Bowers produces the most comprehensive series of bore gauges and internal measuring equipment available, not all applications can be covered by our standard instrument range. In line with our customer care ethos, Bowers has earned a reputation for manufacturing special heads for measuring non-standard applications. The following information illustrates some of the many difficult measuring problems easily solved by these special heads.

### Screw Threads

To measure effective (functional) diameter, pitch diameter, major diameter, between M4 - 300mm. / No. 8 UN - 12" diameter.

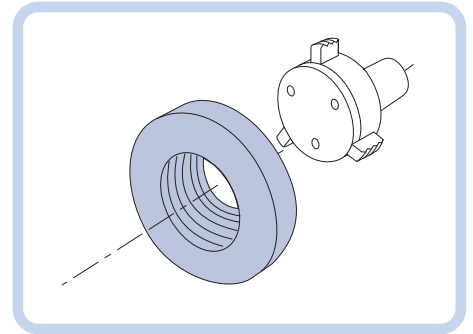

### Grooves

For sizes from 2mm - 300mm diameter.

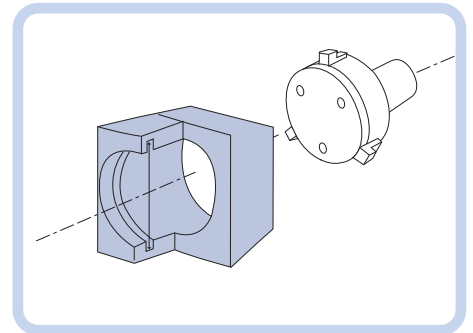

### 2-Point Spline

2 and 3 point heads available.  
Anvils manufactured from tool steel.  
Between pin, major and minor diameter heads available.  
Diameters from 12 - 300mm diameter (1/2" - 12").

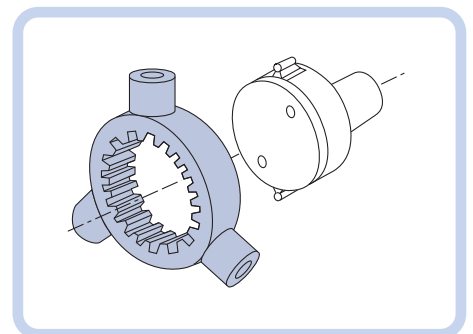

## Special Bore Measurement

The following diagrams illustrate some of the many applications covered by Bowers Specials. Customer quotations for gauges suitable for the measurement of other features can be supplied against a component drawing.

### 2-Point Spherical

2 point available from 3 - 150mm.  
3 point from 6 - 300mm diameter.

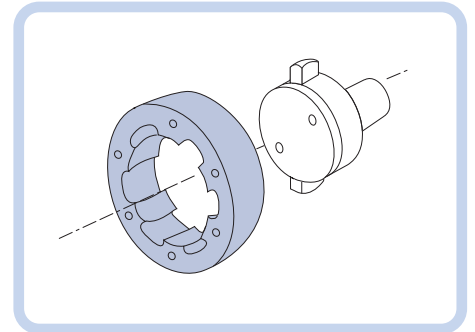

### Ball Screw Threads

From  $\varnothing$  M10

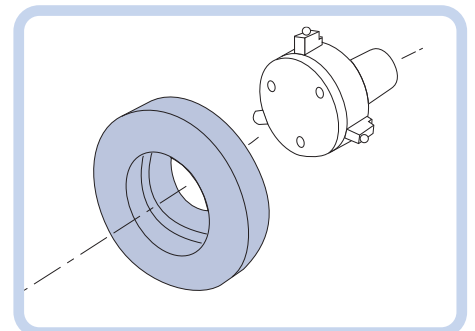

### Deep Hole

Up to 2.0 metres deep with standard extensions.  
Pneumatic system available from 50mm diameter for depths of up to 15 metres.

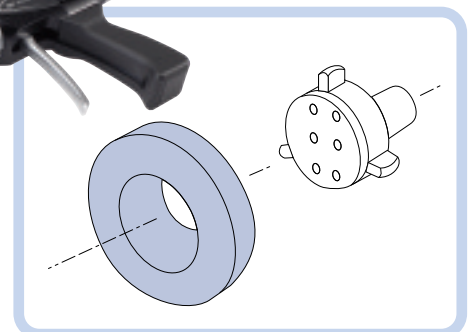

## Special Bore Measurement

### 2 and 3 Point

#### Grooves

For ovality measurement.  
Various anvil forms available.  
Diameters from 6 - 100mm.

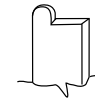
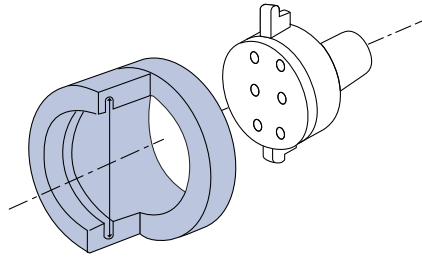

Side view

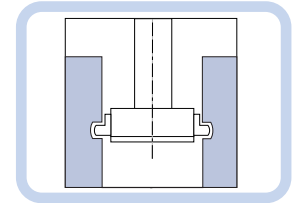

#### Thread

(Also available as 3 point system).

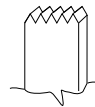
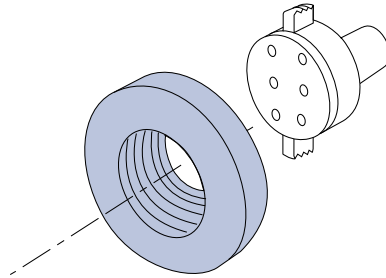

Side view

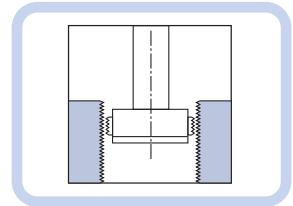

#### Special Length

Diameters from 2 – 6mm can be supplied.  
Length dependent on diameter.

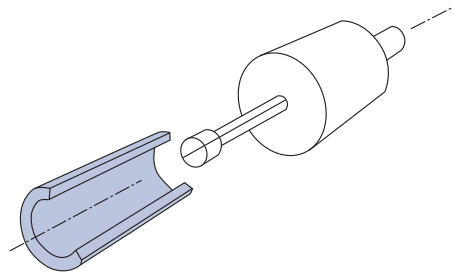

Standard Length

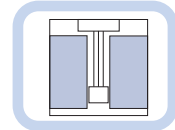
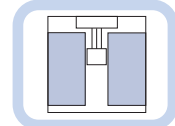

#### Spherical Radius

Can be supplied as a 2 point for ovality or 3 point contact.  
Available from 6 - 300mm.

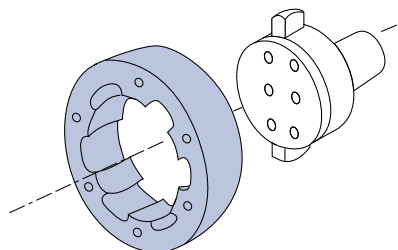

Front view

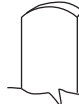

Side view

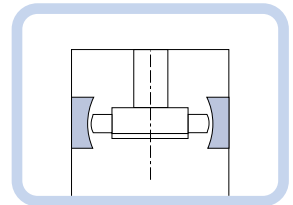

#### Slot Width (Large)

Slot widths from 3 - 100mm.

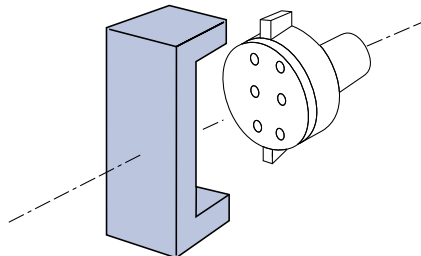

Front view



Side view

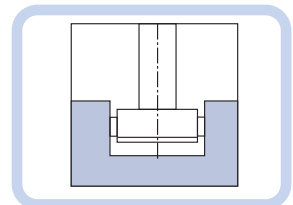

#### Slot Width (Small)

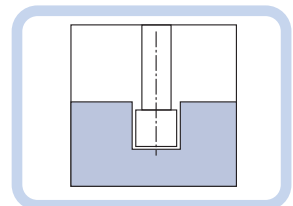
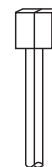
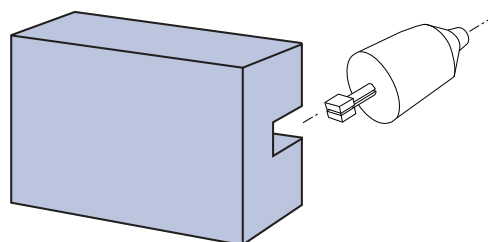

## Taper

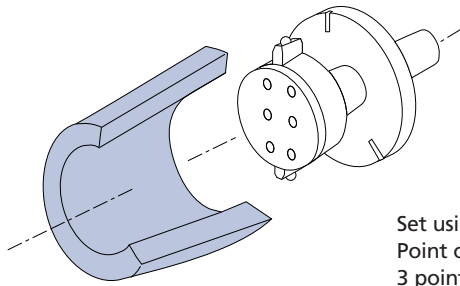

Set using distance 'd' between two heads. Point contact on bore using carbide balls. 3 point also available.

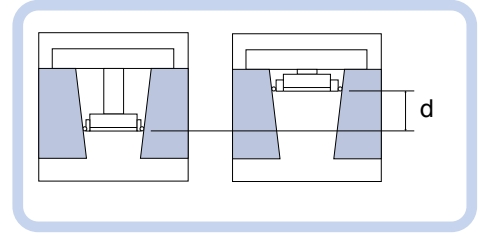

## 3 Point Spherical

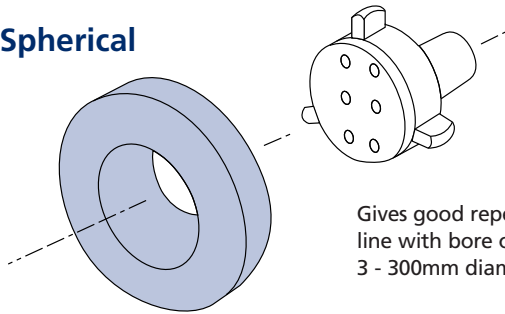

Gives good repeatability even when out of line with bore centre. Available from 3 - 300mm diameter on digital systems.

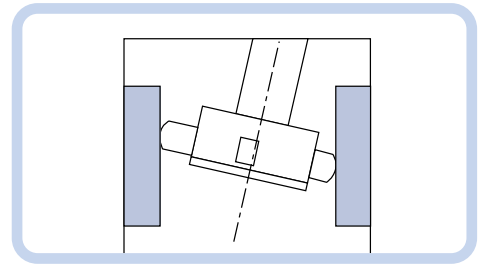

## Irregular Spacing

Available between 16 - 300mm diameter to measure between odd spaced lobes.

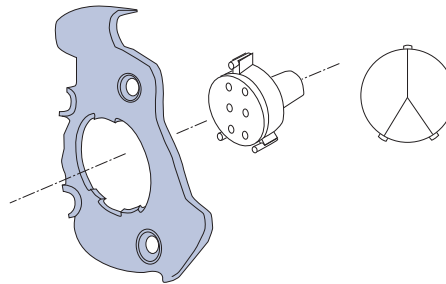

## Deep Hole

For diameters from 20mm, depths up to 500mm. Pneumatic system available for 50mm Ø for depth up to 15m.

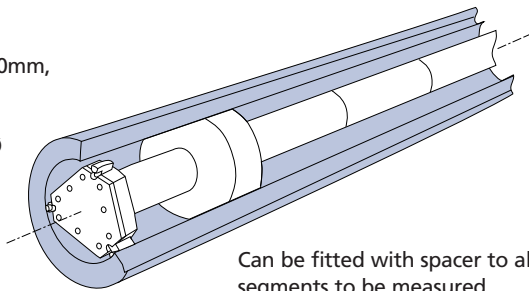

Can be fitted with spacer to allow segments to be measured.

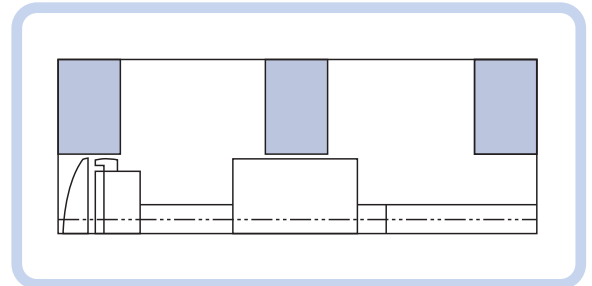

## Internal Splines

3 point heads machined to suit particular spline. Pitch diameter heads fitted with precision formed anvils. Sizes available from 8 - 300mm diameter.

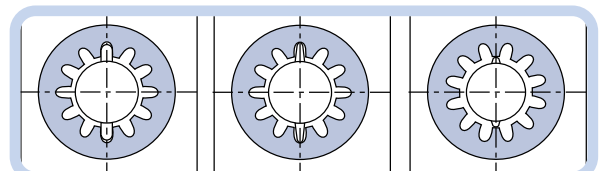
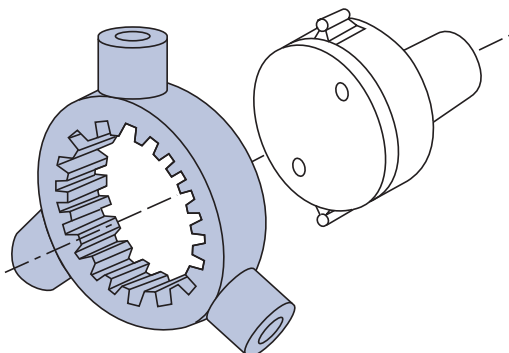

Pitch Diameter

Major Diameter

Minor Diameter

2 Point anvil position

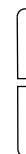

3 Point anvil position

