

## Sylvac Ultra Light Digital Caliper Mark III

Available in seven standard sizes covering most large caliper applications, these revolutionary digital gauges have lightweight reinforced main beams, giving them both incredible strength and an amazing lack of weight, aiding both accuracy and ease of use. All gauge contact faces are titanium coated or solid carbide giving excellent wear resistance. A range of flexible accessories further improves the usefulness of these quality gauges.

**WiFi**  
see p251 for wireless options

**RS232**



### Special Applications

Available on request.

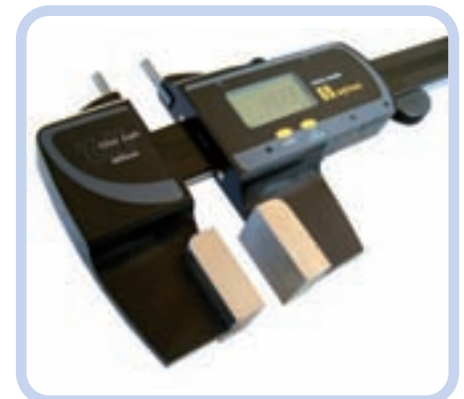

Special\_S\_Cal UL with modified measuring jaws.



Special\_S\_Cal UL with extended measuring jaws.

### Features

- Preset facility for Internal / External measurement
- Constant measuring force applied to measurement
- Hold feature, freezes display for later viewing
- Incremental floating zero
- Metric / inch operation resolution 0.01mm / 0.0005"
- MIN/MAX function
- Tolerance limit indicators
- Hard wearing titanium coated stainless steel external jaws
- Tungsten carbide internal measuring pins
- Large easy to read digital display - 8.5mm digits
- RS 232 output
- Movable left jaw on 1m to 3m models for improved balance
- Water Resistant

External Jaws, titanium coated stainless steel: Length = 150mm, 6"  
Internal Pins, tungsten carbide: Length = 18mm, 0.71". Dia. = 5mm,  
0.2" Measuring Speed = 60" / 1.5m per second

## Ultra Light Accessories

Measurement of threads, grooves and hole centreline distances can be achieved with this range of optional accessories.

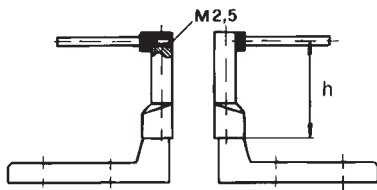
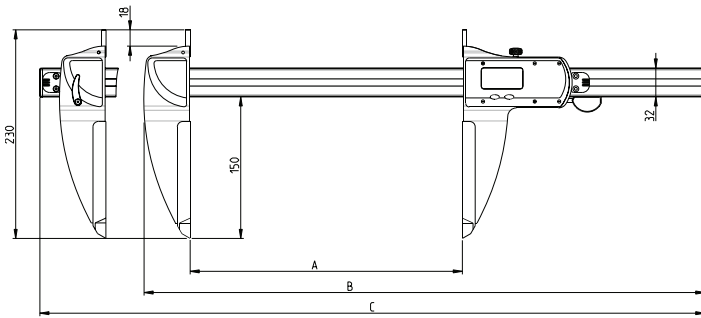

Internal groove measurement.  
Holder for dial gauge contact points

Height (h)	Code No	Price (£)
30mm	30-911-2308	£52.50 Q
60mm	30-911-2309	£97.50 Q

See page 114 for contact points

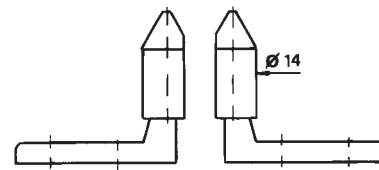

Hole centreline measurement inserts  
in hardened steel, cone 60°

Code No	Price (£)
30-911-2307	£75.00 Q

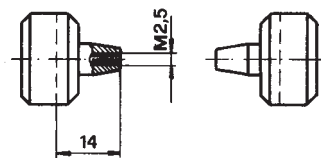

Groove Measurement Holder  
For Dial Gauge Contact Points

Code No	Price (£)
30-911-2305	£68.50 Q

See page 114 for contact points

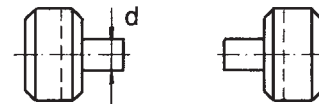

Holder for mounting  
thread measuring wires.

Diameter (d)	Code No	Price (£)
d=6.35mm	30-911-2301	£38.00 Q
d=6.5mm	30-911-2302	£38.00 Q
d=8.0mm	30-911-2303	£38.00 Q

### TECHNICAL SPECIFICATION UL III RANGE

Product	Capacity	Weight	Max error	Repeatability	Code No	Price (£)
ULIII300	300mm / 12"	1.1kg	30µm / 0.0008"	20µm / 0.0008"	30-911-1403	£860.00 Q
ULIII600	600mm / 24"	1.3kg	40µm / 0.0016"	20µm / 0.0008"	30-911-1406	£1,003.00 Q
* ULIII1000	1000mm / 40"	1.6kg	60µm / 0.0024"	20µm / 0.0008"	30-911-1410	£POA Q
* ULIII1500	1500mm / 60"	2kg	150µm / 0.0060"	20µm / 0.0008"	30-911-1415	£POA Q
* ULIII2000	2000mm / 80"	2.3kg	250µm / 0.01"	30µm / 0.0012"	30-911-1420	£POA Q
* ULIII2500	2500mm / 100"	3.5kg	250µm / 0.01"	30µm / 0.0012"	30-911-1425	£POA Q
* ULIII3000	3000mm / 120"	4kg	250µm / 0.01"	30µm / 0.0012"	30-911-1430	£POA Q

\*These models have a movable left jaw for improved balance when measuring smaller parts.